

U 过塑机 使用说明书 USER'S MANUAL

型号: G236LR-011
G330LR-012

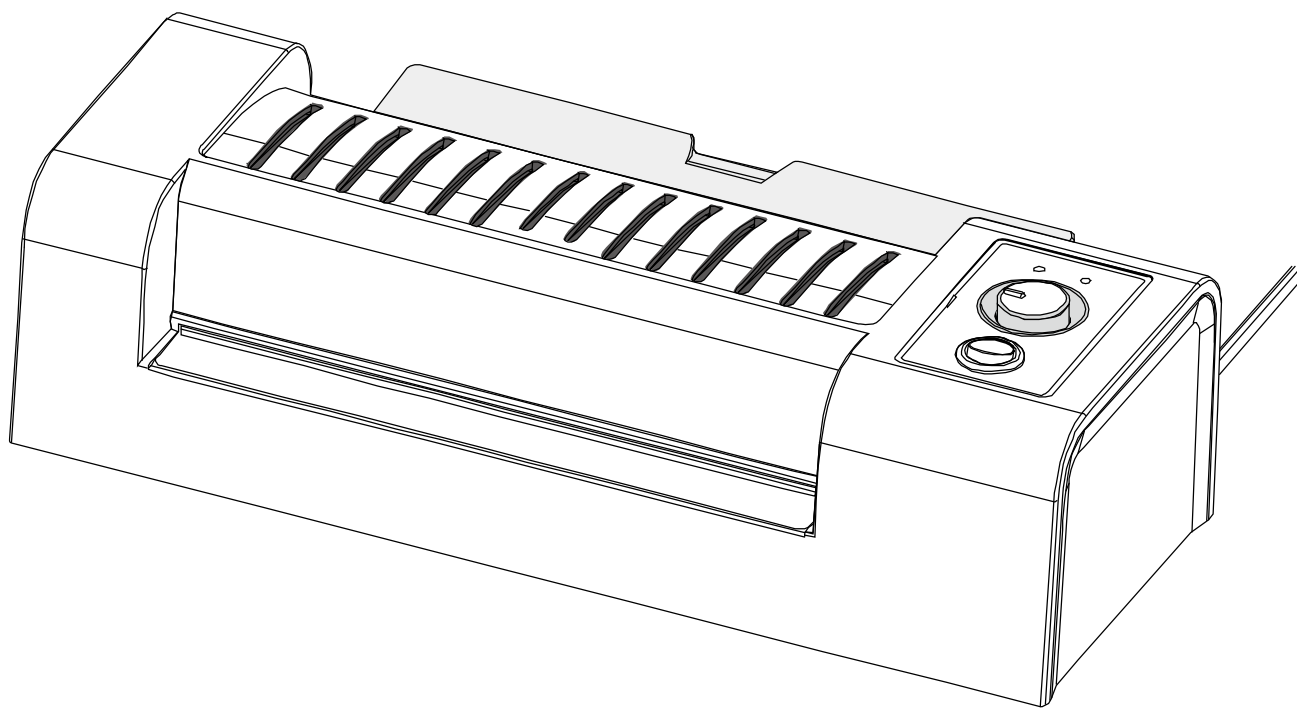

- 升温迅速,温控稳定
- 自动进膜/退膜功能
- 适用80mic~200mic护卡膜
- 热塑、冷裱两用功能

全国联保, 免费客服电话: 800-8574-008

deli 得力集团有限公司
DELI GROUP CO., LTD.

使用时注意事项	1
安全使用说明	2
产品结构及外形名称	3
塑封操作说明	4
保养与维护	4
装箱清单	5
技术参数	5
简易故障处理	6
保修及售后服务	6
Precautions for operation	7
Safety Precautions for Operation	8
Names of Product Structures and Appearance	9
Operating Instruction of Laminating	10
Protection and Maintenance	10
Packing List	11
Technical Parameters	11
Trouble Shooting	12
Guarantee and After-sale Service	12

感谢您购买得力公司生产的过塑机。同时敬请使用本公司的护卡膜(商标名为 deli)。它将纸张照片过塑后,表面光洁、外观漂亮,而且抗水耐磨损。但是一旦塑封后将难以开封,故请务必注意。

为了正确使用该产品,并防止给您及他人带来危害和财产损失,请仔细阅读本手册。

使用时注意事项

警告



危险,请勿让儿童使用。
※ 以免造成伤害。



危险,请勿在机器工作时,用手触摸机器进膜口。
※ 以免造成意外受伤。



危险,请勿在机器工作时,用手触摸机器表面。
※ 以免造成意外受伤。



危险,请勿在操作中将领带、项链等容易卷进机内的服饰靠近机器进膜口。
※ 以免造成意外受伤。



危险,请勿在操作中将头发等接近进膜口。
※ 以免造成意外受伤。



危险,机器在工作时,注意机器表面高温。
※ 以免造成意外受伤。



危险,请勿以任何方式自行分解改造修理机器。
※ 以免造成触电或意外受伤。万一出现物品卷入机内等故障时,请拔下电源插头,然后联系销售网点或售后服务中心,并请听从其指示行事。



危险,切勿向本机泼水。
※ 以免造成火灾或触电。



危险,请勿湿手操作本机器。
※ 以免造成触电或意外受伤。



危险,请勿损伤或加工电源线,勿在电线上放置重物。
※ 以免引起火灾或触电。



万一发生冒烟或有异臭等异常状况时, 请立即切断电源, 中止使用。
※ 以免引起火灾或触电。



万一在使用过程中发生停电状况时, 请在短时间内匀速抽出过塑件, 并拔掉电源插头。
※ 以免引起火灾或触电。



移动机器时, 请务必拔下电源插头。



若机器本体或电源线有任何破损, 请勿使用。
※ 以免引起火灾或触电。



在进行进膜/退膜操作时, 请确认进膜/退膜开关是否接触良好, 否则将造成机器的损坏。(开关接触良好时会有清脆的“啪”声)

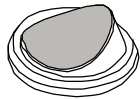

正确状态

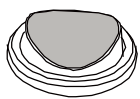

错误状态

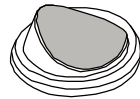

正确状态

安全使用说明 (为保证使用安全, 请务必遵守下列注意事项)

安放场所 (1) 请勿放在潮湿及靠近空调排风口的地方, 以免电线绝缘失灵出现漏电等危险事故。

(2) 请将机器安放平稳。并在塑封机出膜口一侧, 留足足够的空间。

(3) 请勿在机器上放置物品。

(4) 请务必使用AC220V~240V电源。

护卡膜 (1) 本机的护卡膜适合厚度规格为80mic~200mic。建议使用本公司的护卡膜, 如使用其它规格或其它不良护卡膜, 有可能会被卷进机器内。

(2) 建议使用比塑封物大5~6mm的护卡膜。过大或过小都会影响塑封效果。如无大小合适的护卡膜, 也可使用较大的护卡膜。按照下图(A)图示使用, 夹入其它纸张, 待塑封后再将去裁去。

过塑物品 过塑是通过加温、加压进行的, 因操作失误, 有可能会出现护卡膜卷进机内的情况。为此, 请勿塑封下列物品。

(1) 易燃及加热后易熔化的物品(如塑料袋等);

(2) 只有一张的重要物品;

(3) 包括护卡膜在内, 厚度在0.6mm以上的物品;

(4) 感热纸及用蜡笔绘制的图案等加热后会变色、变质的物品;

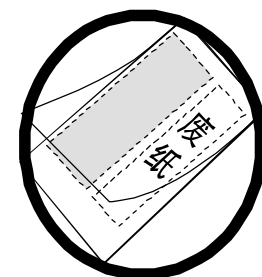

当护卡膜大小不合适时
图(A)

过塑方法

请勿用以下过塑方法：

- | | |
|-------------------------|-------------------|
| (1) 从护卡膜的开口侧放入使用 | (5) 不要前后膜连接使用 |
| (2) 将护卡膜斜放入使用 | (6) 不要把膜剪开使用 |
| (3) 原稿跟膜规格不符, 护卡膜空余部分太多 | (7) 用已变形的护卡膜进行过塑 |
| (4) 原稿自身波浪形或卷曲状态 | (8) 过塑件长度不得小于65mm |

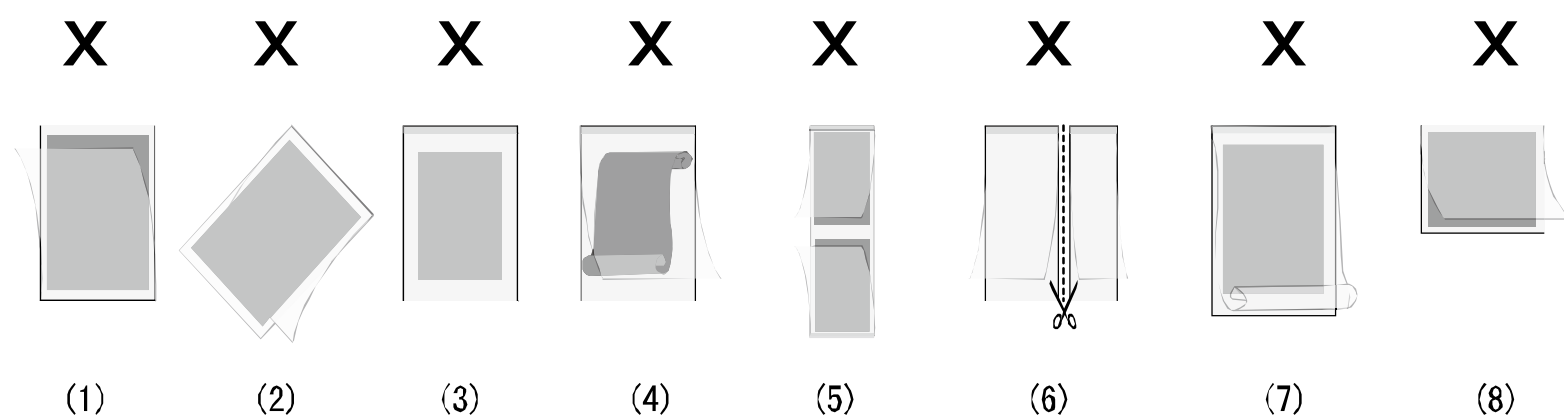

产品结构及外形名称

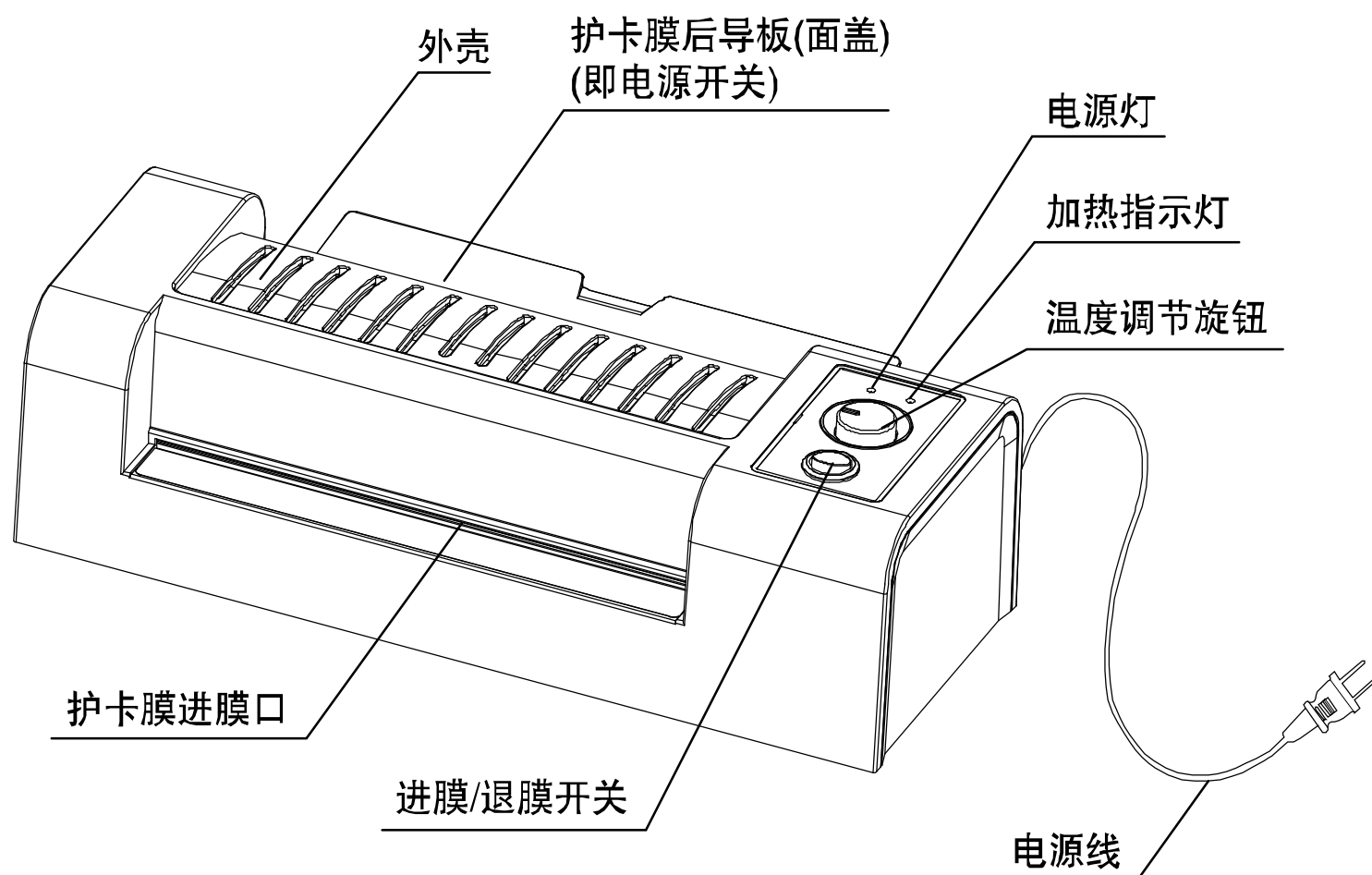

塑封操作说明

- (1) 将电源线接通后,把温度调节旋钮调节到冷裱箭头指示位置,打开后导板即接通电源(机器内部隐藏电源开关自动开启)。此时电源指示灯(红色)亮起,电机启动(图示A)。

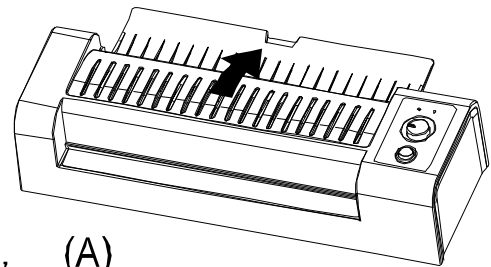

- (2) 如需热塑胶,采用热塑封的护卡膜,根据所用护卡膜的厚度规格,将温度调节旋钮调到与护卡膜厚度相对应的箭头指示位置。此时加热指示灯(绿色)会闪烁表示在加热,机器预热约7分钟,待加热指示灯(绿色)由闪烁变为长亮时,表示机器预热完成,可以过塑。如过塑件出现白雾状或在护卡膜中间出现纵向波纹上翘或撕开不粘胶,表示设定的温度过低,此时需提高设定温度;如过塑件出现横向波纹或有气泡,表示设定的温度过高,此时需降低温度(图示B)。

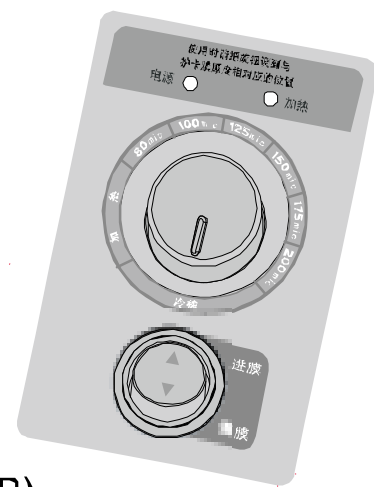

- (3) 如需将过塑件退出或塑件斜放、卡件时,可按下退膜按钮,过塑件将自动从进膜口退出,或用手辅助拉出(图示C)。

- (4) 过塑完成后,为确保安全,把温度调到冷裱指示位置,空转冷却5-10分钟后,关闭后导板,拔下电源插头。

- (5) 在刚开机时如需冷裱,采用冷裱膜,把温度调节旋钮调到冷裱箭头指示位置,可以直接过塑。

- (6) 在热塑封使用一段时间后如需冷裱,采用冷裱膜,把旋钮调到冷裱箭头指示位置,空转冷却10分钟后方可过塑。

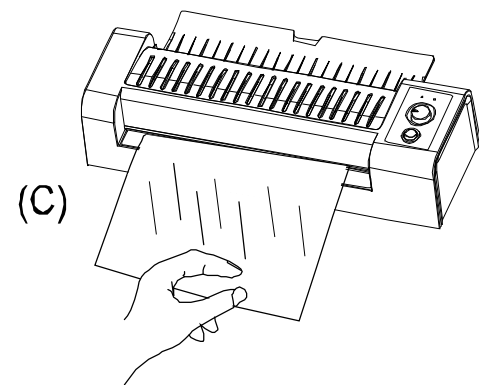

保养与维护

- (1) 胶辊清洁:过塑机长期使用后,胶辊上会粘上熔融的塑料残渣,易导致护卡膜卷入机器内,而且这些塑料残渣一旦凝固会很难清除,因此请仔细清除。

清洁步骤:请将日历、商品目录等中等厚的纸张不夹护卡膜,用最高档温度过塑数次即可。

- (2) 过塑机清洗:清洗前请拔掉电源插头,用含少量水份的湿布擦拭,不允许用汽油、酒精、稀释剂清洗,更不允许用金属刷子和工具刷、铲子敲打胶辊,以免划伤胶辊。

- (3) 机器长时间停机不用时,请用合适的罩子将整机罩住以防灰尘。

装箱清单

序号	名称	数量	备注
1	过塑机	1台	
2	使用说明书	1份	
3	产品保修卡	1份	
4	产品合格证	1份	

技术参数

货号	No.3891	No.3892
型号	G236LR-011	G330LR-012
最大过塑宽度	236mm(A4幅面)	330mm(A3幅面)
功率	310W	410W
电压	AC220V ~240V	
最大过塑厚度	≤0.6mm(包括护卡膜厚度)	
过塑速度	300mm/min	
温度范围	85°C~145°C	
加热方式	外部加热	
噪声	≤ 55dB	
预热时间	约7min	
产品尺寸	373x145x103mm	466x145x103mm
产品净重	2.1kg	2.8kg

进步性能改良,恕不另行通知,规格允许误差±5%

简易故障处理

异常现象	常见原因	处理方法
过塑件出现白雾状或在护卡膜中间出现纵向波纹上翘或撕开不粘胶。	机器温度过低（选择的膜厚档位与护卡膜的厚度规格不一致）。	根据护卡膜的厚度规格将膜厚档位调节旋钮调到相对应的中间位置（或微调提高温度）。待加热指示灯（绿色）停止闪烁后，再把过塑件重新进行过塑。
	塑封物件受潮	将塑封件干燥后再进行塑封
塑封件产生超皱(波纹)或气泡	没有选择与护卡膜相对应的温度, 导致机器内温度过高	降低设定温度, 按护卡膜的厚度把温度调节旋钮置于相对应的刻度位置, 约待机10分钟后再塑封
绿灯在闪烁, 机器不加热	机器内加热装置已烧坏	此时须联系售后服务中心或专业电工解决
机器不工作, 电源指示灯不亮	电源插头与插座接触不良	检查电源插头与插座是否接触不良
	超温保护器或保险管烧断	此时须联系售后服务中心或专业电工解决
	面盖未打开	打开面盖
电源指示灯（红色）、加热指示灯（绿色）长亮, 进膜口不会自动吸入护卡膜。	进膜/退膜按键设定在退膜状态	设定到进膜状态
	过塑件未插到位	过塑件插入碰到胶棍为止
	内部传动已损坏	此时须联系售后服务中心或专业电工解决
塑封件从入口进去未从出口出来	塑封件卷进机内	马上按下退膜按钮
	内部传动已损坏	此时须联系售后服务中心或专业电工解决

保修及售后服务

保修期内，如属正常使用情况下出现的故障，请通知当地代理店。但是由于过塑操作失误所引起的故障则不属于保修范围之内。

Thank you for buying the laminating machine of Deli Company. Please use the laminating film (trade mark: **Deli**) of our company correspondingly. Paper and photos laminated by it feature smooth and clear surface, beautiful appearance as well as waterproof and wear-resistance properties. However please note it is impossible to remove the film after laminating

For correct operation of the machine and prevention of injury and damage to properties, please read this manual carefully before operating.

Precautions for Operation

Warning



Danger. Please do not let children use it.
※ To prevent body injuries.



Danger. Please do not touch the film inlet while the machine is running.
※ To prevent accidental injuries.



Danger. Please do not touch the surface of machine while it is running.
※ To prevent accidental injuries.



Danger. Please do not let such accessories as the tie, necklace etc. close to the film inlet during operation.
※ To prevent accidental injuries.



Danger. Please do not let the hair close to the film inlet during operation.
※ To prevent accidental injuries.



Danger. Attention: the surface of machine has a high temperature when the machine is running.
※ To prevent accidental injuries.



Danger. Do not disassemble, alter and repair the machine in any way on your own.
※ To prevent electric shock or accidental injuries. In case faults such as products rolled into the machine occur, please pull out the power plug and call distribution outlets or after-sale service center. Do in accordance with their instructions.



Danger. Do not water the machine.
※ To prevent fire or electric shock.



Danger. Do not operate the machine with wet hands.
※ To prevent electric shock or accidental injuries.



Danger. Do not break or process the power wire and do not put heavy products on the wire.
※ To prevent fire or accidental injuries.



In case abnormal situations happen including fuming or having unpleasant smell and so on, please cut off the electricity and stop operating.
 ※ To prevent fire or electric shock.



In case the power is off during operation, please take out the laminated object immediately and pull out the power plug.
 ※ To prevent fire and electric shock.



Please do not forget to pull out the power plug before moving the machine.



Please do not use it if there is any damage to the machine or the power wire.
 ※ To prevent fire or electric shock.



Please confirm the state of feeding/retracting during operation. (See figure)

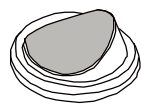

Correct

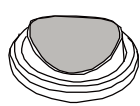

Error

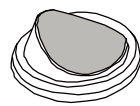

Correct

Safety Precautions for Operation

(Please observe the following instructions to make sure a safe operation.)

- Places (1) To prevent such accidents of electric leakage and so on caused by isolation failure, do not place it in wet areas and places close to outlet of air conditioner.
- (2) Please place the machine steadily and leave sufficient space to the film eject of laminating machine.
- (3) Do not put heavy products on the machine.
- (4) Please use electric power of AC220V-240V.

Laminating Film (1) The suitable thickness of the laminating film is 80mic~200mic. We suggest using the film of our company. Films of other specifications or poor qualities may be rolled into the machine.

- (2) It is suggested that the laminating film should be 5~6mm larger than the object being laminated. Too large or too small film may affect the laminating effects. If no suitable laminating film is available, use bigger one. Do as what the following figure shows. Insert other paper and cut the superfluous part after laminated.

The Laminated Object Laminating is carried out through heating and adding pressure. Inappropriate operation may make the laminating film rolled into the machine. Therefore, please do not laminate the following objects.

- (1) Products which are flammable and liable to be melted after heated (such as plastic bags, etc.);
- (2) Important objects which only have one copy;
- (3) Products with thickness over 0.6mm, including the thickness of the laminating film;
- (4) Objects whose colors and quality may be changed after heated, such as thermal paper and pictures with patterns drawn by crayons;

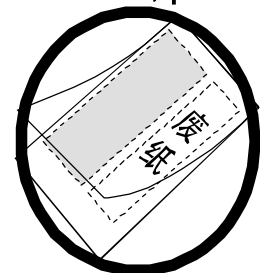

When the laminating film doesn't fit
 Figure (A)

Laminating Methods

DO NOT adopt the following laminating methods:

- (1) Put the open side of the laminating film in the machine.
- (2) Put the laminating film into use when it is tilted.
- (3) The specifications of the originals and the laminating film are not fit for each other, in which film are much larger than the original.
- (4) The original is rippled or curled.
- (5) Use two pieces of film successively.
- (6) Cut film for laminating.
- (7) Use deformed film for laminating.
- (8) The length of laminating film is less than 65mm.

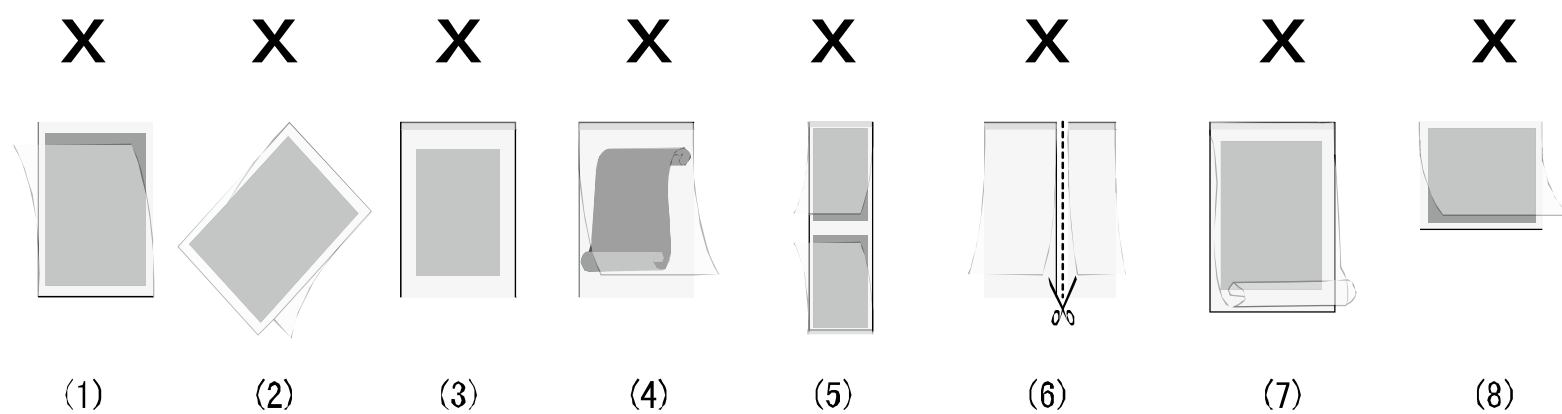

Product Structure and Appearance

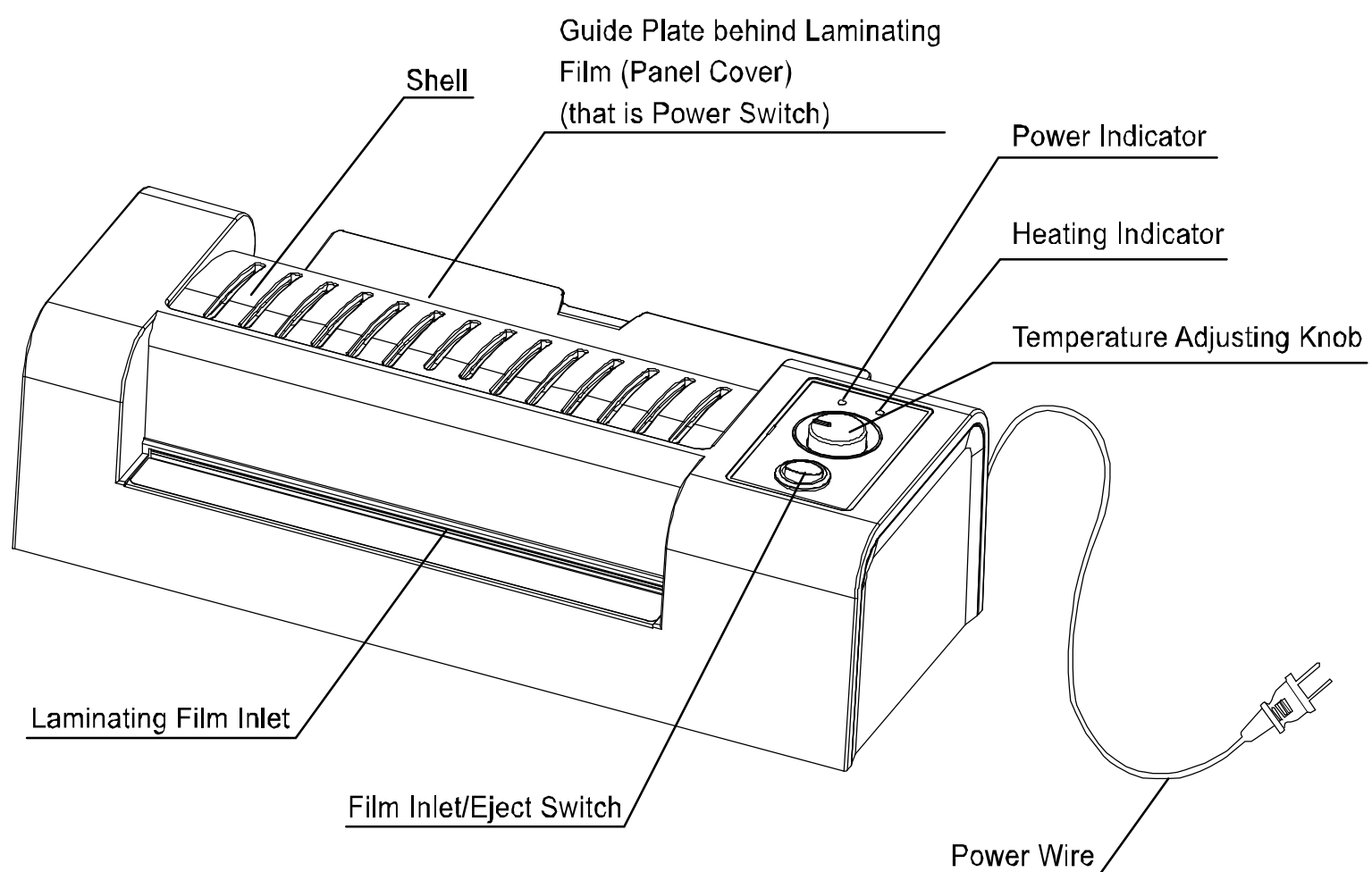

Operating Instruction of Laminating

- (1) Connect the power plug then turn the temperature adjusting knob to the position indicated by the cool laminating arrowhead. Open the back guide plate which is also the way to power on (the power switch hidden inside turns on automatically). At this moment, the power indicator (in red) lightens and the machine starts up (fig. A).

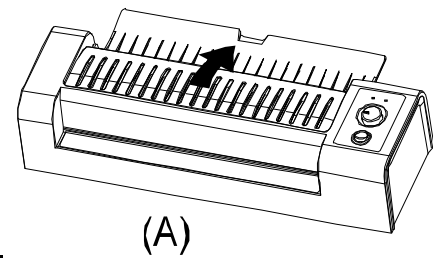

(A)

- (2) If hot plastic cement is needed, adopt heat laminating film. Turn the temperature adjusting knob to the position indicated by the arrowhead which is corresponding with the thickness of the adopted film. At this moment, the heating indicator (in green) becomes to flashes indicating that it is heating. After about 7mins' for preheating, the heating indicator lightens and stops flashing, indicating that it finishes preheating and is ready for laminating. If the laminated objects are wrapped by white fog, or upward vertical ripples are appearing on the laminating film or the adhesive tape breaks away from its original place, it means the temperature set is not high enough and it is necessary to increase the temperature; however, if transverse ripple or air bubbles appear on the laminated object, it means the temperature set is too high and has to be decreased (fig. B)

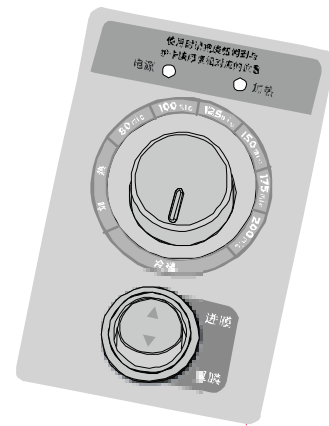

(B)

- (3) If the laminated object has to be taken out or if it is tilted or locked, press the film eject button and the laminated object will come out of the film inlet automatically or use hand to help to pull it out. (fig. C)
- (4) After laminating, in order to make sure it is safe, please adjust the temperature to the position indicated by the cool laminator and after letting it run without laminating for about 5-10min, turn off the back guide plate and then pull out the power plug.

- (5) If cool laminating is needed, adopt cool laminating film. Turn the temperature adjusting knob to the position indicated by the cool laminating arrowhead and begin to laminate directly.

- (6) If cool laminating is needed after the hot laminating has been operated for a period of time, adopt cool laminating film. Turn the temperature adjusting knob to the position indicated by the cool laminating arrowhead and begin to laminate only after the machine running without laminating for 10min.

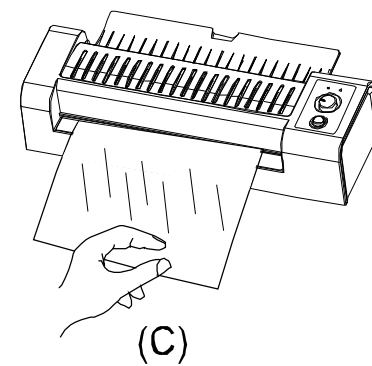

(C)

Protection and Maintenance

- (1) Clean the rubber roller: after being used for a long time, melted plastic leavings will be adhered on the rubber roller, which is liable to make laminating film roll into the machine. In addition, these leavings are hard to be removed once they become solid. Therefore, please clean the rubber roller carefully. Cleaning procedures: laminate paper with medium thickness, such as calendar, catalog and so on, at the highest grade temperature many times without laminating film.

- (2) Clean the laminating machine: pull out the power plug before cleaning. Clean it with slightly wet cloth. Do not use gasoline, alcohol and thinner to clean the machine. It is even more unallowable to use metal brush, tool brush and scoop to knock the rubber roller which may damage the roller.
- (3) Please use proper hood to cover the machine to keep away from dust if the machine won't be used for a long time.

Packing List

NO	Name	Quantity	Remark
1	Laminating Machine	One set	
2	Instruction Manual	One copy	
3	Warranty Card	One copy	
4	Quality Certificate	One copy	

Technical Parameters

Product No	No.3891	No.3892
Model No	G236LR-011	G330LR-012
Maximum Length of Laminating	236mm(A4 size)	330mm(A3 Size)
Power	310W	410W
Voltage	AC220V ~240V	
Maximum Thickness for Laminating	≤ 0.6mm (including the thickness of film)	
Laminating Speed	300mm/min	
Temperature Range	85°C~145°C	
Heating Method	Heating outside	
Noise	≤ 55dB	
Time for Pre-heating	About 7min	
Product Size	373x145x103mm	466x145x103mm
Net Weight	2.1kg	2.8kg

We won't issue additional notices for improvements of properties. The specifications allow ±5% errors

Trouble Shooting

Abnormal Phenomena	Reasons	Treatments
Laminated objects are wrapped by white fog, or upward vertical ripples are appearing on the laminating film or the adhesive tape breaks away from its original	Machine temperature is too low the thickness of the chosen of the laminating film are inconsistent).	Move film thickness adjustment control to the corresponding position to accommodate the thickness of laminating film (or slightly increase the temperature). Laminate the objects when heating indicator (in green) stop flashing.
	Laminated objects are affected by damp	Laminate objects when they are dried.
Laminated objects are crumpled up (with ripples) or are full of air bubbles	Temperature chosen is not corresponding to the film temperature, which leads to the overheating of the machine.	Reduce the initiated temperature, and place temperature controller to the scale that is suitable to the thickness of the film. Start laminating 10 minutes after the new temperature is set up.
Green light is flashing but the temperature does not increase	Heating device in the machine is burnt out.	Contact after-sale center or call for professional electrician
Machine stop operating, power indicator is not on	Power plug is not connected properly with the electrical outlet	Check whether power plug and the electrical outlet is properly connected
	Overheating protector or tube fuse is burnt out	Contact after-sale center or call for professional electrician
	Panel is not open	Open the panel
Power supply indicator (in red), heating indicator (in green) always bright, inlet does not automatically suck in laminating film.	Inlet/Eject button is initiated at film ejection position	Adjust the button to the inlet position
	Laminated objects are not properly installed	Laminated objects shall be inserted to the rubber roller
	Internal transmission is broken	Contact after-sale center or call for professional electrician
Laminated objects go into the inlet but do not come out of the outlet	Laminated objects are rolled into the machine	Press eject button immediately
	Internal transmission is broken	Contact after-sale center or call for professional electrician

Guarantee and After-sale Service

Please contact local agents for the repairing of malfunctions caused by normal operation within the guarantee period. However, guarantee does not cover malfunctions caused by misuse of the machine.

deli

得力集团有限公司

DELI GROUP CO., LTD.

地址: 浙江 宁海县黄坛镇车站西路128号

Add: No.128, Bus Stop West Road, Huangtan
Town, Ninghai County, Zhejiang

电话(Tel):0574-65278888

传真(Fax):0574-65273660

[Http://www.deli-stationery.com](http://www.deli-stationery.com)

执行标准: Q/NDL 63
