

deli得力

U 过塑机 使用说明书 USER'S MANUAL

No.3890

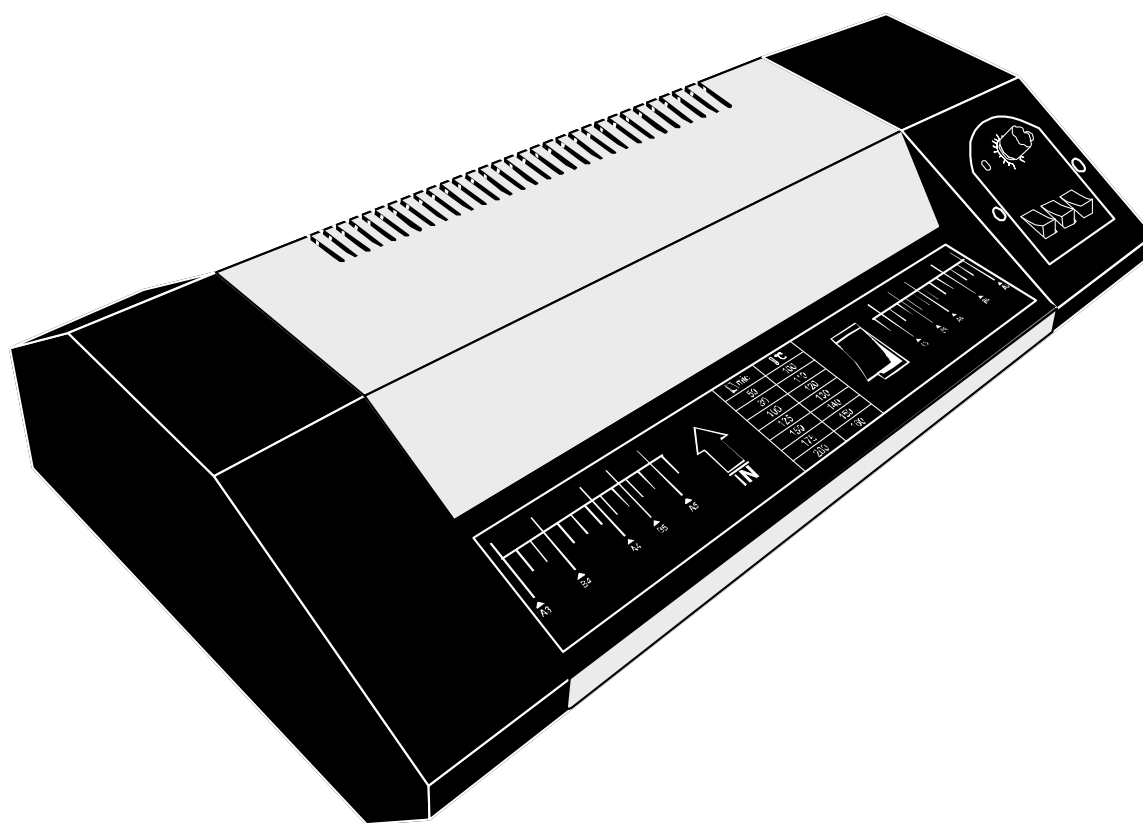

全国服务热线: 400-185-0555

产品外形结构及名称 PRODUCT STRUCTURE & NAMES

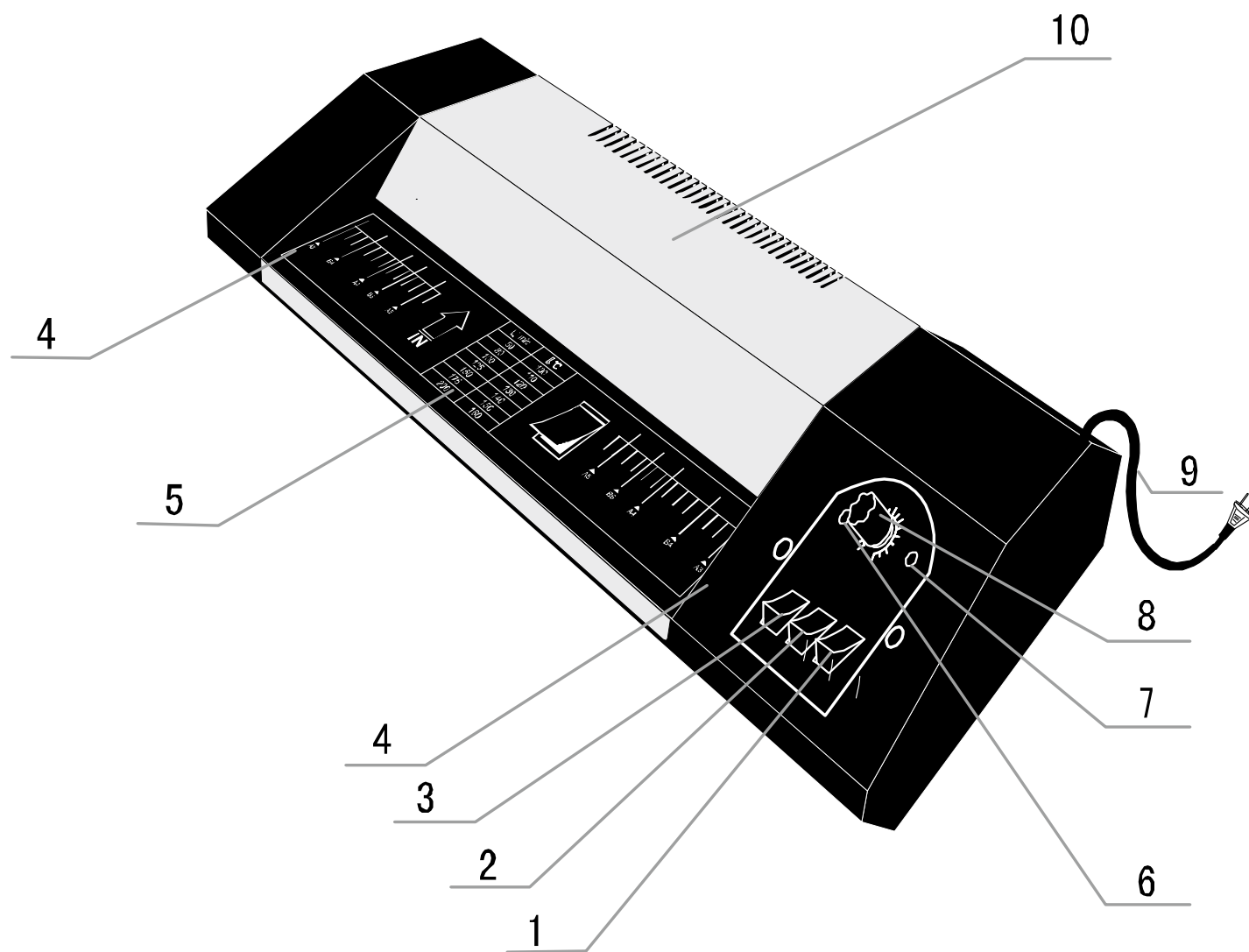

1. 电源开关 POWER SWITCH
2. 顺转/逆转开关 CLOCKWISE/COUNTER CLOCKWISE SWITCH
3. 塑封/冷裱切换开关 LAMINATING TRANSFER SWITCH
4. 最宽过塑刻度棱线 THE WIDEST LAMINATING CREST LINE
5. 塑封膜进口 LAMINIATING ENTRANCE
6. 工作指示灯 WORKING INDICATOR LIGHT
7. 预热指示灯 HEATING INDICATOR LIGHT
8. 调温旋钮 TEMPERATURE SET BUTTON
9. 电源线 POWER WIRE
10. 上盖 COVER

安全说明

1. 本产品为电器类产品，您与他人的安全都十分重要，请在使用前阅读并保留这些说明书；
2. 过塑机应放置在干燥，清洁的地方，并远离易燃易爆品；
3. 机器在运作时请勿将与本产品无关的任何物品塞入设备；
4. 在工作中请勿接触机壳上盖，以免烫伤，严禁在机壳上放置杂物，以免发生意外；
5. 请勿自行拆卸修理，如机器出现异常现象(如噪音、异味、卡膜等)不能正常工作时，请立即关闭电源开关，拔掉电源插座，并请专业人员维修；
6. 禁止在火炉旁或潮湿的环境下使用该设备，手湿时请勿触摸插头，同时保持底座干燥；
7. 不可以过塑金属制品(铁、铝、铜等)；
8. 请在靠近插座的地方使用机器，以便紧急切断电源；
9. 插上电源前，请确保电源开关处于“关闭”位置；
10. 机器使用完毕，先将“塑封”开关切换到“冷裱”档，待散热后（温度低于80℃）在关闭电源开关，机器停用时请拔掉电源插头；
11. 电源线与插头损坏时请勿使用。

操作步骤

1. 插上电源，打开电源“启动”开关，电源灯(红)亮，电机开始工作；
2. 打开“封塑”开关，开始升温；
3. 将旋钮设定在过塑机所需要的温度位置上，预热3-5分钟左右。当温度上升到设定温度时工作灯重复亮-暗几次，温度趋于稳定，这时就可以进行塑封工作。在工作过程中，恒温灯会出现闪烁，重复亮-暗变化，这表示机器内部恒温系统正在加热-停止加热的切换中，属于正常现象；
4. 塑封前确定按钮处于“顺转”位置，将所塑封的卡片装入塑封膜内，离袋子密封端留出约2毫米，待绿灯亮时，把塑封膜已封口的一端插入机器中，如果将未封口的一端或塑封膜密封端与所塑封的卡片一端间隙太大插入机器中，则易产生皱褶或塑封膜缠绕在胶辊上或堵塞现象；
5. 冷裱时，打开上盖，“启动”开关，将“封塑”开关处于“冷裱”位置，即可操作。
6. 如刚进行过热塑封操作而需转换到冷裱状态时，必须等待产品表面完全冷却后才能进行冷裱操作。

注意:塑封膜插入机器时，请按规格放在相应的指示线条内。

塑封温度

该机属于调温型。在25℃室温下，推荐右边表格里的温度档位，根据您选用的塑封膜大小、厚度、材质等因素，还需进行调整；温度过低，卡片图像迷糊不清，这时应当增加设定温度；温度过高，会使塑封膜产生皱纹，这时应当降低设定温度；当塑封膜规格在200mic以上时，塑膜请选用170℃-180℃温度档。

mic	℃
50	100
80	110
100	120
125	130
150	140
175	150
200	160

使用提示

1. 进行塑封时如厚度过厚不能正常塑封，将“顺转”开关切换至“逆转”位置，即可退出被塑物；
2. 塑封完毕后，塑封膜可能很烫很软，请小心对待，可用书本或其它平整重物压一下塑封物，有助保持表面平整。

技术参数

电源电压	AC 220 V 50 Hz
电源电流	<3 A
功率	600 W
塑封宽度	320 mm
产品尺寸	530x225x100 mm
塑封膜最大尺寸	A3
最大塑封厚度	≤1mm
预热时间	3-5min
塑封速度	360 mm/min
噪音	≤60 dB

清洗与维护

1. 清洗前请拔掉电源插座，用软布蘸酒精擦拭，不允许用汽油、稀释剂清洗，更不允许用金属刷子和工具刷、铲敲打胶辊；
3. 机器长时间停机不用时，请用合适的罩子将整机罩住以防灰尘。

CAUTIONS

1. This is electronic equipment, your safety as well as others' is important. Please read and follow these instructions.
2. Laminating machine should be placed in dry and clean places, far away from the flammable matters.
3. During operation, please do not insert anything into the machine other than laminating films and suggested items, the machine is only used for laminating.
4. During operation, do not touch the upper cover to avoid scald, do not put the objects on the outer case to avoid accident.
5. Never disassemble, repair, or redesign the machine by yourself, if machine can not work normally because of some exceptional phenomena, for example, noise or has bad smell or the film is locked, please turn off and unplug the machine immediately. Please contact expert for repairs.
6. Never use the machine near a stove or in a humid environment, do not touch the plug with wet hands or immerse the base in any liquid.
7. The object to be laminated CANNOT be metal (iron, aluminium, copper, etc.)
8. Install the socket-outlet near the equipment and keep easy access, in order to cut power by emergency.
9. Before plugin, keep the power "off".
10. After laminating, transfer the button to "cold", then switch off the power after cooling.
11. Do not operate the machine with damaged power cord or plug.

OPERATING PROCEDURE

1. Insert the plug into the power socket, turn on the power switch and power lamp is on (red), then the electric motor begins to work normally.
 2. Turn on the preheating power and begin to preheat, the temperature rises rapidly.
 3. Set the button on the temperature position desired and preheat for about 3-5 minutes. When the temperature rises up to the set temperature and the working lamp will be on and off for several times. The temperature trends to the steady, this time, you can carry out the plastic sealing work. During the working procedure, the constant lamp will occur to twinkle, repeated light and dark changes. It means that constant temperature system inside the machine is at the convert in heating stopping to heat and belongs to normal phenomenon.
 4. Before operating, keep button on "veer" state, insert the plastic sealing cards into the protective film; leaving a 2mm border from the sealed edge of the pouch, when the green light is on, insert the sealed end of the card protective film into the machine. If insert unsealed end into the machine, fold or the card protective film rounds the offset or the block phenomenon would occur.
 5. When use "cold", open "start" switch on upper cover and keep "sealing" switch to "cold" position, then start operation.
 6. If switch to cold laminating after hot laminating, do not operate the machine until the laminated item to be cold completely.
- NOTICE: When the card protective film is inserted into the machine, it must be placed into the two crest lines of the card entrance plate.

PLASTIC SEALING TEMPERATURE

This machine is temperature adjustable. Under the 25°C room temperature, we recommend you to set the temperature as the table beside shows. At the same time, you should also adjust the temperature according to the size, thickness and material of the laminating film you use. If the temperature is too low, the card picture will get vague and you should increase the setting temperature. If the temperature is too high, the laminating film will get wrinkled and you should reduce the setting temperature. When the laminating film is over 200 mic, please set the temperature at 170-180°C.

mic	°C
50	100
80	110
100	120
125	130
150	140
175	150
200	160

CLUE TO USE

- 1.If the laminated item is too thick to be laminated, Please transfer the button from "clockwise" to "counter-clockwise" to get out the item.
- 2.When the film exits after being laminated, it may be very hot and soft, Handle the laminated pouch carefully, press the item with a book or any other heavy objects may help to make it flat and smooth.

TECHNICAL DATA

Mains voltage	AC 220 V 50 Hz
Consumption	<3 A
Power	600 W
Max width	320 mm
Size of the machine	530x225x100 mm
Size of film of utilizable	A3
Film of utilizable thickness	≤ 1mm
Heating up time	3-5min
Speed	360 mm/min
Noise	≤ 60 dB

CLEANING AND CARE

- 1.Unplug the product from the wall outlet before cleaning, use the soft cloth with alcohol. Do not use the gas or thinner, metal brush and tool brush, shovel and knocking the rubber roller are prohibited.
- 2.If left unused for a long time, please cover the machine to prevent dust.

得力集团有限公司

DELI GROUP CO., LTD.

地址: 浙江宁海得力工业园

Add: Deli Industry Zone, Ninghai County,
Zhejiang Province, China

电话 (Tel): 0574-65278888

传真 (Fax): 0574-65273660

Http://www.nbdeli.com

MADE IN CHINA

