

deli得力

U 碎纸机使用说明书 USER'S MANUAL

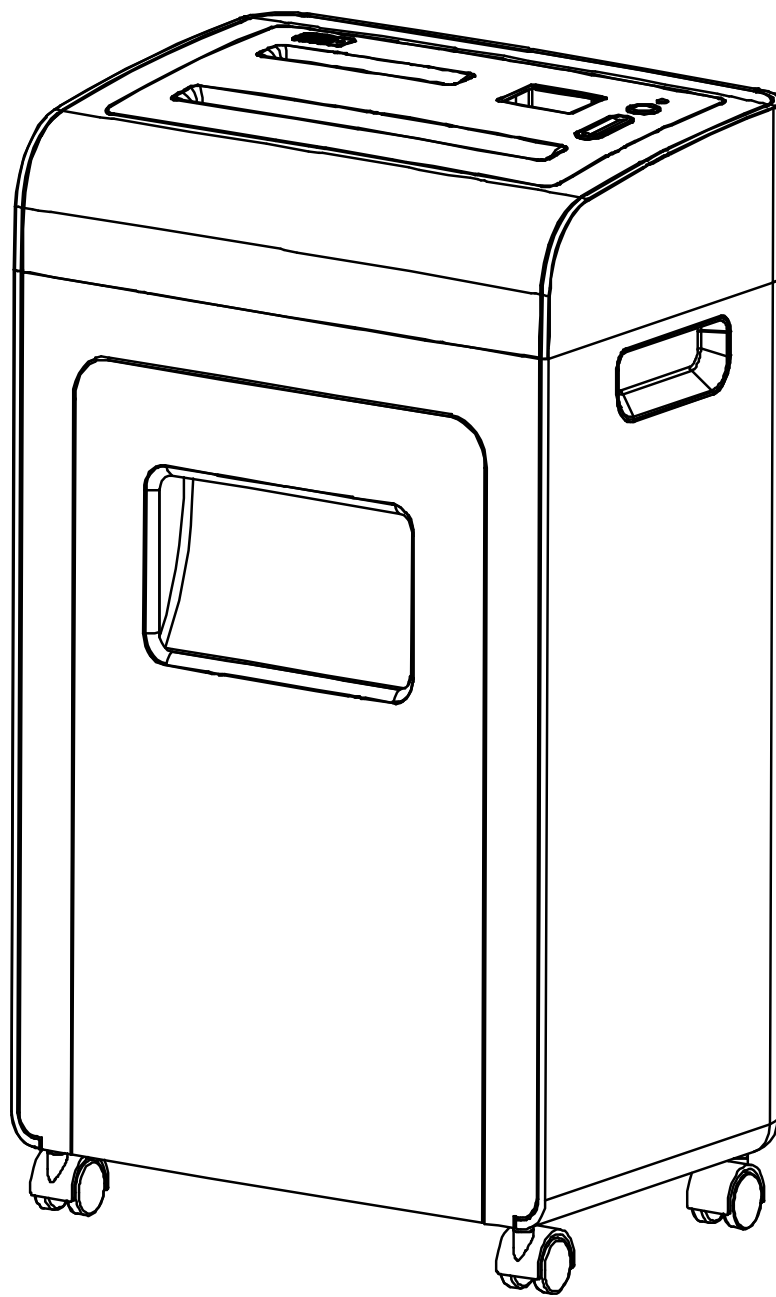

ARTICLE NO. :

9913 9913A 9914 9914A 9915 9915A

9917 9917A 33044 33045

目 录

CONTENT

使用时注意事项	1
产品规格	2
装箱清单	2
产品外形结构及名称	3
使用说明	3
保养方法	4
常见故障分析及排除	4
回收	4
Useage attention	5
Product Specifications	6
Packing List	6
Product Outlook & Names	7
Operating Procedures	7
Maintenance	8
Trouble Analysis & Troubleshooting	8
Recycle	8

使用产品前请仔细阅读本使用说明书 (Please read User's Manual carefully before operation)

感谢您购买得力公司碎纸机,其先进功能和典雅的设计适合个人和部门级办公使用。我们确信这系列碎纸机强大的碎纸能力和相当的保密程度将使您在处理文件时更加得心应手。

为了正确使用该产品,并防止给您及他人带来危害和财产损失,使用前请仔细阅读本手册。

使用时注意事项



请将本机放置在平稳的地方,请注意不要翻倒。
※ 以免机器摔伤出现故障而不能正常使用。



危险,切勿以任何方式自行分解、改造、修理机器。
※ 以免造成触电或意外受伤。



危险,切勿湿手操作电源插头。
※ 以免造成触电或意外受伤。



倒粉碎物、移动或在一段时间不使用该机器时,
请拔下插头,切断电源。
※ 以免引起火灾或触电。



请勿向本机泼水。
※ 以免引起火灾或触电。



请勿在加热或制冷的机器旁,高温多湿,布满灰尘的地方使用。
※ 以免引起火灾或触电。



危险,请勿损伤或加工电源线,勿在电线上放置重物。
※ 以免引起火灾或触电。



万一发生冒烟或有异臭等异常状况时,请立即切断电源,中止使用。
※ 以免引起火灾或触电。



若机器本体或电源线有任何破损,请勿使用。
※ 以免引起火灾或触电。

▲ 注意



危险, 切勿让儿童使用。
※ 机器内部有刀刃, 以免造成伤害。



危险, 切勿用手触摸纸张投入口或排出口的刀刃部分。
※ 机器内部有刀刃, 以免造成伤害。



勿将领带、项链、衣袖等卷入进纸口。
※ 如不慎卷入, 请按住“反转/REV”钮, 然后除去。



勿将头发等卷入进纸口。
※ 如不慎卷入, 请按住“反转/REV”钮, 然后除去。



勿将大头针、回形针等投入入纸口。
※ 如不慎卷入, 请按住“反转/REV”钮, 然后除去。

产品规格

货号	9913/9913A	9914/9914A	9915/9915A	9917/9917A	33044	33045
电源	AC220V/50Hz	AC220V/50Hz	AC220V/50Hz	AC220V/50Hz	AC220V/50Hz	AC220V/50Hz
功率(W)	190	255	255	320	255	320
碎纸类型	段状	段状	段状	段状	段状	段状
碎纸效果(mm)	3x16	2x6	3x15	4x40	3x15	4x40
碎光盘效果(片状)		5	5	5	5	5
碎纸能力(70g, A4)(张)	6	6	10	16	10	16
碎纸速度(m/min)	≥2	≥2	≥2	≥2	≥2	≥2
入纸口宽度(mm)	220	230	230	240	230	240
入光盘口宽度(mm)		122	122	122	122	122
纸屑桶容量(L)	15	21	21	31	21	31
机器外形尺寸(mm)	330x203x510	370x235x545	370x235x545	390x270x615	370x235x545	390x270x615
噪音(dB)	≤70	≤70	≤70	≤70	≤70	≤70
机器净重(kg)	7.5	10	10	14.8	10	14.8
连续工作时间(min)	5	10	10	10	10	10

装箱清单

序号	名称	数量	备注
1	碎纸机	1台	
2	使用说明书	1份	
3	产品保修卡	1份	
4	合格证	1份	

产品外形结构及名称

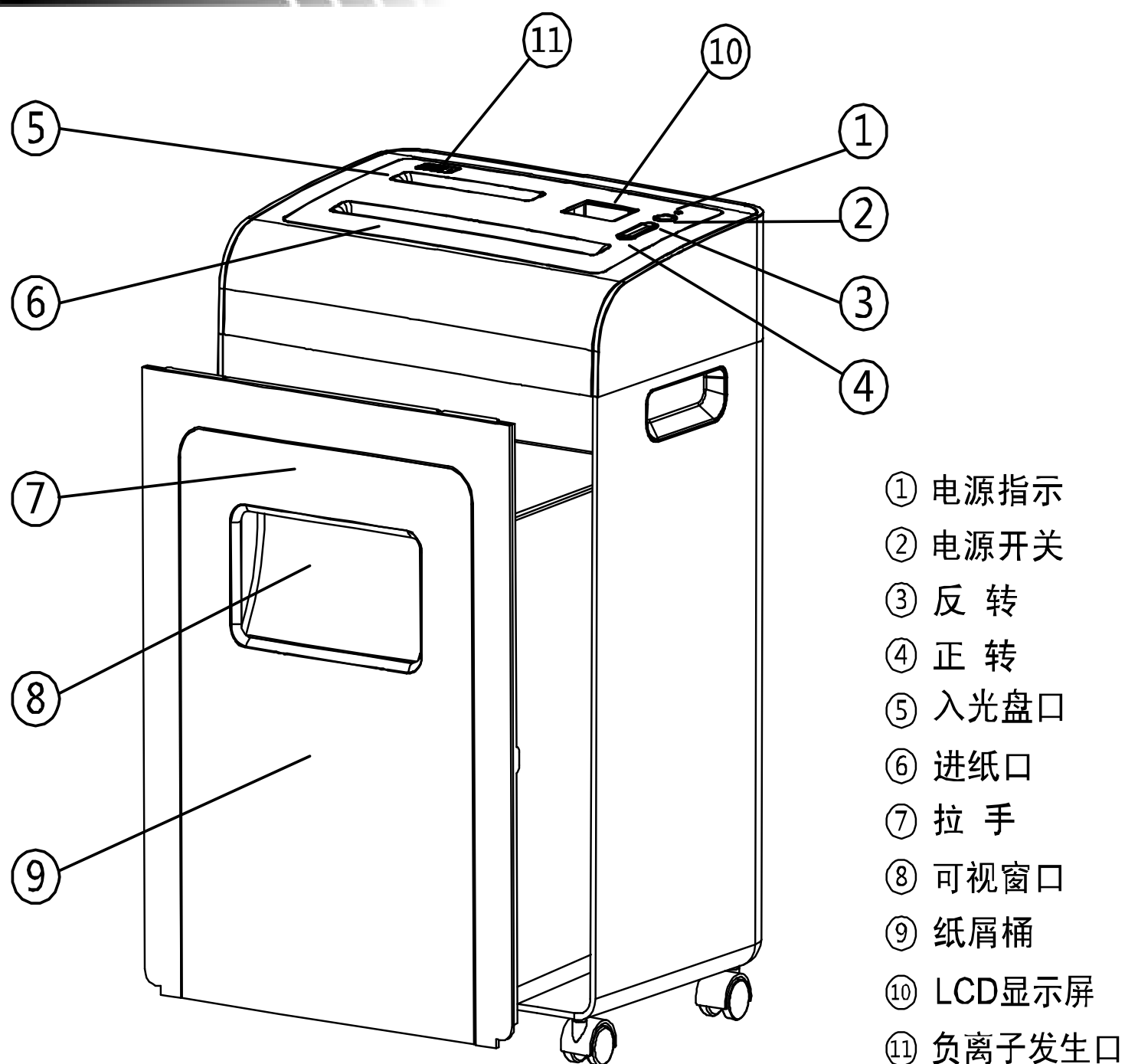

(图片仅供参考, 产品以实物为准)

使用说明

1. 对照您的机器电压规格, 接通220V电源。
2. 按下电源开关“①”按钮, 指示灯亮绿灯, 即可开始碎纸, 碎完后自动待机, 等待下一次碎纸。当您使用完毕后, 请再按一下电源开关“①”按钮, 关闭电源。
3. 当您想中止正在粉碎的文件时, 可按下手动退纸开关“反转”按钮, 机器会马上反转将您的文件退出。
4. 当您碎纸过量产生卡纸时, 红色指示灯会提示, 电机会自动反转将纸退出, 然后会自动停机。您拿出纸后指示灯又变为绿灯, 等待下一次碎纸; 如果机器自动退纸失败, 可按下手动退纸开关“反转”按钮, 将过量的纸退出。若被卡纸张太短不能用手取出时, 亦可交替按下手动进纸开关“正转”按钮将纸张碎掉以清除卡纸现象。
5. 纸屑装满时自动声光报警, 正常碎纸功能被锁定, 清除纸屑后机器恢复正常工作。
6. 机器连续大量碎纸会使电机温度过高, 碎纸机自动停机(这是特设的电机过热自动保护功能)。自动停机后, 等待一段时间(约30分钟)后, 机器可重新工作。

保养方法

1. 保养前，必须拔掉电源插头；
2. 保养维护只限机器外部零件的清理；
3. 清洁外部时，注意不要让水滴滴入机器内部。

清洁机器外壳时，要用软布沾上软性肥皂水或清洁剂轻轻擦拭，注意擦拭布不可掉入进纸口内，且不可使用汽油、苯类、稀释剂等有机溶剂和去污粉。

常见故障分析及排除

故障现象	故障原因分析	故障排除方法
机器不工作	电源插头未插好, 无电源	插好电源
	供电电压过低	提供额定工作电压
	纸屑桶未推入预定位置, 无电源	推入纸屑桶
	机器因长时间连续工作, 电机过热进入保护状态	等待机器自然冷却
	纸张太透明	附加一张不透明纸或将透明纸多次折叠
	纸屑桶已满	清倒纸屑
	过载负荷未解除	适当减少碎纸张数, 重新放入碎纸口
机器堵转	卡纸	选择“反转”按钮, 将过量纸张退出
机器转动不停	进纸口光敏管处有纸屑和其它异物	清除干净
机器噪音大	地板中空或机器未放平衡	调整机器放位

注: 当您的机器故障状况用上述方法不能排除时, 请立即停止使用, 并切断电源, 通知本公司当地服务单位进行处理, 切勿擅自拆卸!

回收

请务必将废旧的电子产品及包装材料送交到专门的回收点, 这样可以防止废弃物处理不受控制并帮助推动材料回收。

Instruction Manual

Thank you for your purchase of DELI Paper Shredder, which is provided with advanced function and elegant design for home office or department office. We are confident that the shredder will make a major contribution to destroy used documents and ensure the confidentiality of sensitive materials. help you correctly use the shredder and prevent you and others from suffering hazards and property losses, please read this manual carefully.

Useage attention

Warning



Place the shredder in a steady place and do not overturn it.
※ Otherwise there is the possibility of breaking the machine.



Unauthorized disassembly, rebuilding or service of the shredder is not allowed.
※ Otherwise there is the possibility of electric shock or injury.



Do not handle power plug by wet hands.
※ Otherwise there is the possibility of electric shock.



Plug out the power plug from the socket of power supply when dumping paper scraps, moving the shredder or laying the shredder aside for a long time.
※ Otherwise there is the possibility of fire or electric shock.



Do not sprinkle water to the shredder.
※ Otherwise there is the possibility of fire or electric shock.

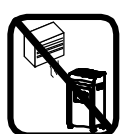

Do not put the shredder beside any heating or cooling equipment or in a place where there is high temperature, excessive moist or lots of dust.
※ Otherwise there is the possibility of breaking the machine.



Do not damage or process the power line. Do not put heavy objects on the power line either.
※ Otherwise, there is the possibility of fire or electric shock.



In case of abnormal situations such as emission of smoke odor, please stop using the shredder.
※ Otherwise there is the possibility of fire or electric shock.



If the shredder and power cable have any breakage, please do not use it.
※ Otherwise there is the possibility of fire or electric shock.

Caution



Danger! Keep out of reach of children.
 ※ Blade inside machine. Protect yourself against injury.



Danger! Never touch the blade.
 ※ Blade inside machine. Protect yourself against injury.



Keep ties or sleeves away from paper-feeding opening to avoid pulling-in.
 ※ When accident happens, press "REV" button and then take them out.



Keep hair away from paper-feeding opening to avoid pulling -in.
 ※ When accident happens,press "REV" button and then take it out.



Keep clip, pins or staples away from paper-feeding opening to avoid pulling-in.
 ※ When accident happens, press "REV" button and then take them out.

Product Specifications

Article No.	9913/9913A	9914/9914A	9915/9915A	9917/9917A	33044	33045
Voltage	AC220V/50Hz	AC220V/50Hz	AC220V/50Hz	AC220V/50Hz	AC220V/50Hz	AC220V/50Hz
Power supply(w)	190	255	255	320	255	320
Shred type	cross cut	cross cut	cross cut	cross cut	cross cut	cross cut
Shred size (mm)	3x16	2x6	3x15	4x40	3x15	4x40
CD Shred effect (pcs)		5	5	5	5	5
Shred capacity(70g A4) (sheet)	6	6	10	16	10	16
Shred speed (m/min)	≥2	≥2	≥2	≥2	≥2	≥2
Entrance width (mm)	220	230	230	240	230	240
CD Feeding width (mm)		122	122	122	122	122
Waste-bin volume (L)	15	21	21	31	21	31
Dimensions (mm)	330x203x510	370x235x545	370x235x545	390x270x615	370x235x545	390x270x615
Noise (dB)	≤ 70	≤ 70	≤ 70	≤ 70	≤ 70	≤ 70
Net weight (kg)	7.5	10	10	14.8	10	14.8
Continuous working time(min)	5	10	10	10	10	10

Packing List

No.	Item	Quantity	Remark
1	Shredder	1	
2	Instruction manual	1	
3	Guarantee card	1	
4	Passed certificate	1	

Product Outlook & Names

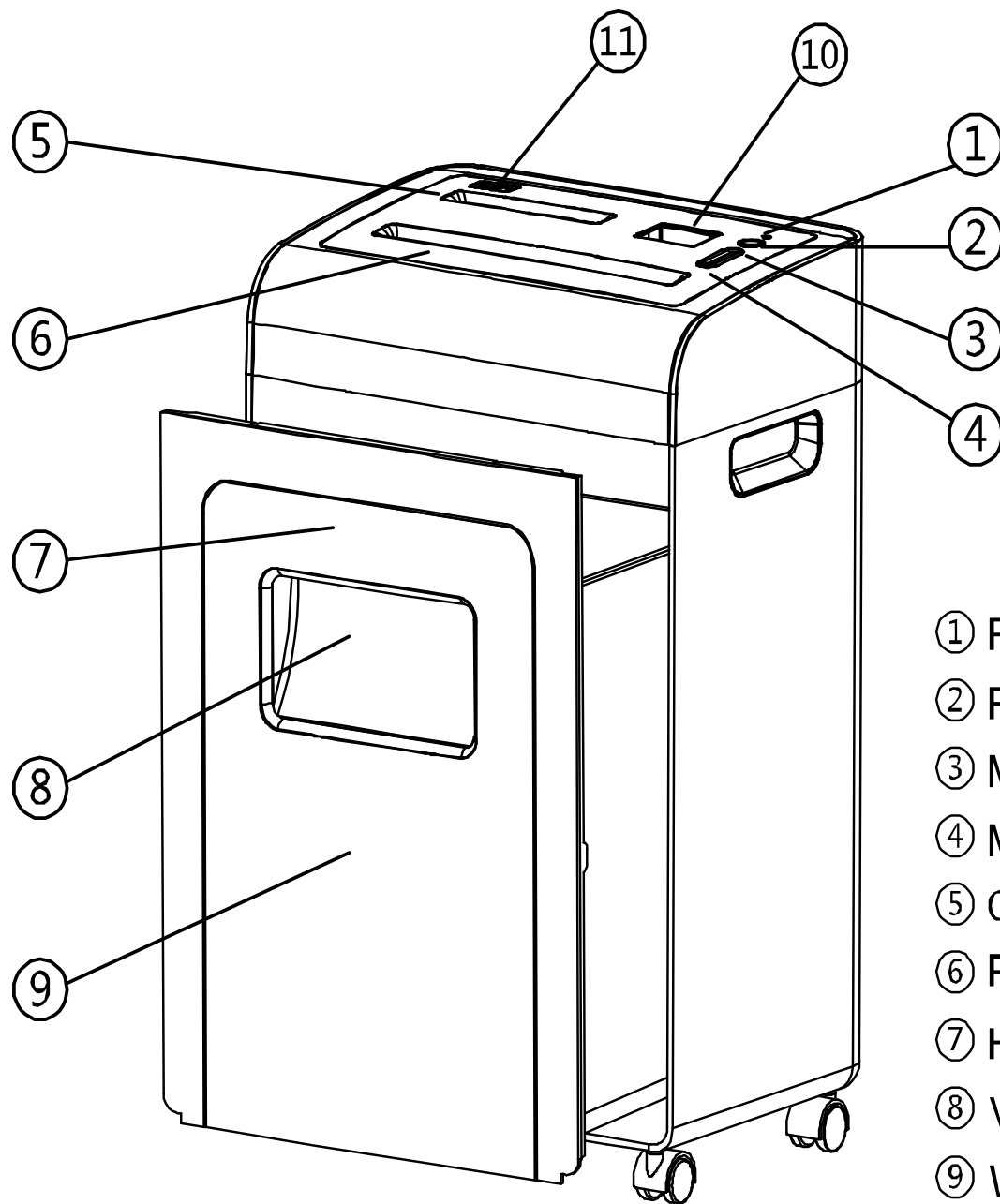

- ① Power indicator
- ② Power switch
- ③ Manual reverse
- ④ Manual feed
- ⑤ CD entrance
- ⑥ Paper entrance
- ⑦ Handle
- ⑧ Visible screen
- ⑨ Waste-bin
- ⑩ LCD screen
- ⑪ Negative ions generator

(Picturer only for reference,pls take product for maferial object as standard)

Operating Procedures

1. Connect the power cable & plug.
2. Press the power switch button and the indicator light will turn green, indicating that the machine is ready. The machine will start to shred automatically and resume the standby mode afterward. Press the power switch button again to shut down the machine after using.
3. When you want to stop the operation of shredding paper, you can press "REV" button for sending out them.
4. If paper blocked in case of overload ,the indicator light will turn red , the motor will reverse automatically to send out the paper,and the machine will automatically stop. Take out th paper, and the light turns green.
5. When the waste-bin is full, the machine will alert automatically. After empty the container,the machine will run again after a moment.
6. When the inside temperature is too high after continuous working, there is an overheat protection for the motor to shut off automatically at this time.Let the shredder cool down for 30minutes before operating again.

Maintenance

1. Pull out the power plug from the socket of power supply before maintenance
2. The maintenance by user is only limited to cleaning visible surface of the shredder.
3. When cleaning the surface of the shredder, do not allow water to drop into the interior of the shredder.

Use cloth dipped with small amount of soap water to clean the exterior of the shredder. The cloth must be closely wrapped around hands during cleaning, so as to avoid the cloth to drop into the paper entrance, and it is prohibited to use organic solvents such as gasoline, benzenes solvents or dilution agent to do the cleaning. Decontamination powder must not be used too.

Trouble Analysis & Troubleshooting

TROUBLE	TROUBLE ANALYSIS	TROUBLESHOOTING
SHREDDER NO RUNNING	plug disconnect, no power	connect the plug
	lower voltage	provide the rated power
	if not put the waste-bin into the scheduled position, no power	push the waste-bin into scheduled position
	automatically stop running to prevent motor from over heating	wait for motor cooling down naturally
	paper is too transperence	fold paper or add thicker paper
	waste-bin fullled	empty waste-bin
	overload not relieve	reduce the number of paper and feed again
TURN IN BLOCKED	jammed paper	select the " manual reverse" button to get the excessive paper out
CONSTANTLY RUNNING	particles at the paper feed opening	clean up
NOISE LOUD	floor is hollow or machine not located steadily	adjust location

In case the above solutions are not able to remove any trouble of the shredder, please stop using it immediately, disconnect the power plug and switch off power supply. Contact the local service agency of our company for disassembly and service of the shredder.

Recycle

Please send the wasted electronic products and packaging materials to specialised recycle station, since it is helpful to improve waste treatment and material recycling.

得力集团有限公司

DELI GROUP CO., LTD.

地址: 浙江宁海得力工业园

Address: Deli Industry Zone, Ninghai County,
Zhejiang Province, China

电话 (Tel): 0574-65278888

传真 (Fax): 0574-65273660

Http://www.deli-stationery.com

MADE IN CHINA

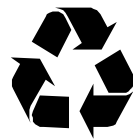

全国免费热线:

800-8574-008 (座机) 400-185-0555 (手机)