

deli得力

U 胶圈装订机 使用说明书 USER'S MANUAL







No.3871
得力集团保留产品设计与说明书的修改权, 恕不另行通知。

得力集团有限公司
DELI GROUP CO., LTD.
地址: 浙江宁海得力工业园
Address: Industry Zone, Ninghai County,
Zhenghai Province, China
E-mail: 0574-65273888
Tel: 0574-65273888
Fax: 0574-65273890
Website: www.deli.com.cn
全国服务热线: 800-8574-008

Direction for use

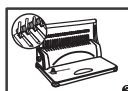
- The machine is used for punching of paper and plastic sheet, and plastic clip is used for loose-leaf binding. The machine only can be used for this purpose, and please use it according to the operation instruction.
- Before punching of the original materials, do remember to use waste paper to test whether the machine works normally.
- Empty the waste container periodically.
- The upper limit number for punching is 12, and this number shall not be exceeded.

- Insert paper and adjust "Trim Mode" to centre the paper. Select adjustable cutters to set hole punching.
- Push down the handle to punch holes, then lift back to the original place.
- Place the plastic rings to the back of comb opening upward.
- Push the handle backward and let the hooks engage the rings to open the plastic rings.

使用说明

- 该机器用于纸张和塑料片穿孔, 并用塑料夹活页装订。该机器仅限此功能, 请遵照操作说明使用。
- 对原件穿孔前切记在废纸上先行试用确认机器正常。
- 定期清空废料容器。
- 穿孔上限为12张, 请勿超出。







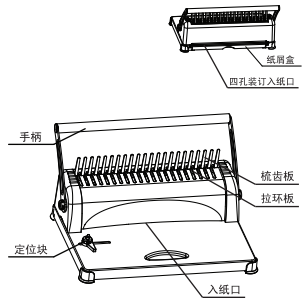

- 根据装订文本大小, 选择定位纸块和装订边距位置, 插入文本。
- 插入文本后, 将手柄下压, 抬起手柄。
- 将胶环置于梳状板后面, 开口向上。
- 向后推手柄, 拉开放环。

首先感谢您购买得力公司 No.3871 胶圈装订机, 其多种功能和典雅的设计适合个人和部门级办公使用。我们确信这款功能齐全的胶圈装订机将使你装订文件更加得心应手。为了正确使用该产品, 并防止给您及他人带来不便, 请仔细阅读本手册。

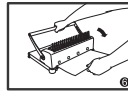
产品外形结构及名称

- Insert the binder into the plastic rings. Push the handle backward and forward of the last.
- The binding machine has four-hole binding function.

Common fault analysis and troubleshooting

Fault phenomenon	Fault cause analysis	Troubleshooting method
It is hard to press the handle when paper punching.	There is paper scrap or other hard object in the paper cutting part. The operation is beyond the punching capacity described in the instruction.	Take out the sundries with chipboard. Operate according to the requirements of the instruction.
The punching edge distance has indication phenomenon.	The two sides of the incoming paper are unbalanced. There is paper scrap or other hard object in the paper cutting port.	The two sides of the incoming paper are unbalanced. Take out the sundries with chipboard.
The open rubber ring has indication phenomenon.	The comb plate has deformation caused by collision. The draw hook of pull ring plate has deformation.	Straighten the comb plate with a ruler. Push the pull ring to calibrate the draw hook with hands.
Excessively paper punching or the paper is hard to punch out.	The number of pieces of paper for punching at a time is too large.	Reduce the punching thickness of each time (based on the requirements of the instruction).
The paper cannot reach the bottom.	The paper is unsmooth and the paper edge coils.	Smoothen the paper and then reoperate.

Product parameters

Maximum punching thickness: 12 pieces of paper (80g- A4 paper)
Binding edge distance: 3mm
Distance between holes: 14.3mm
Binding specification: A4 paper or below
Maximum binding thickness: 350 pieces (Ø)

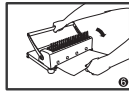
- 将打孔后的文件套在胶环上, 将手柄拉回, 文本装订完成。
- 装机后面附加四孔装订。

常见故障分析及排除

故障现象	故障原因分析	故障处理方法
打纸时手柄压不下	切纸口里有纸屑或其它硬物 超出纸张上的打孔能力操作	用硬纸板把杂物取出 按说明书要求进行操作
打孔边距倾斜	进纸两边不平衡 切纸口里有纸屑或其它硬物	进纸两边不平衡 用硬纸板把杂物取出
拉开的胶圈倾斜	梳齿板受碰撞变形 拉环板拉钩变形	用直尺校准梳齿板 用手把拉钩校正
打纸不成或纸屑难推出	一次打纸过多	减少一次打纸厚度 (按说明书要求)
纸卷差不到底	纸卷卷曲, 纸边沾有粘粒	把纸展平后再, 重新打纸

产品参数

最大打孔厚度: 12张(80克A4纸)
装订边距: 3mm
孔间距: 14.3mm
装订规格: A4纸以下
最大装订厚度: 350张(Φ30mm)

Thank you for purchasing No. 3871 rubber ring binding machine of Deli Company. The multiple functions and elegant design make the product applicable to individual use and department use. We believe that the rubber ring binding machine with complete functions will make your document binding have higher efficiency. To make you correctly use the product and prevent the inconvenience caused to you and other people, please carefully read this manual.

Product apparent structure and the names

